

FETTEROLF

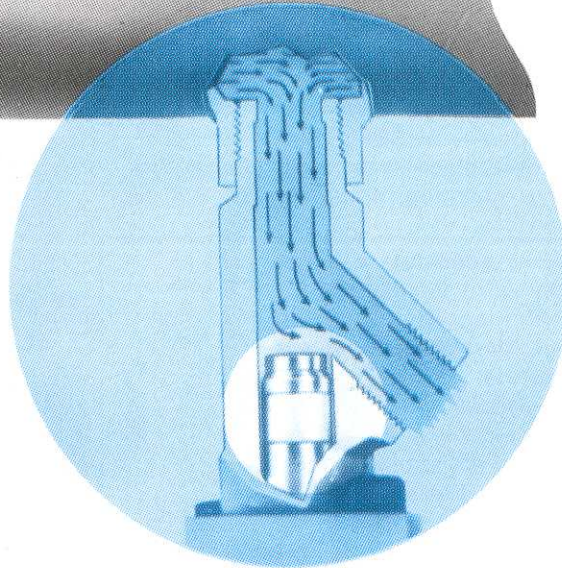
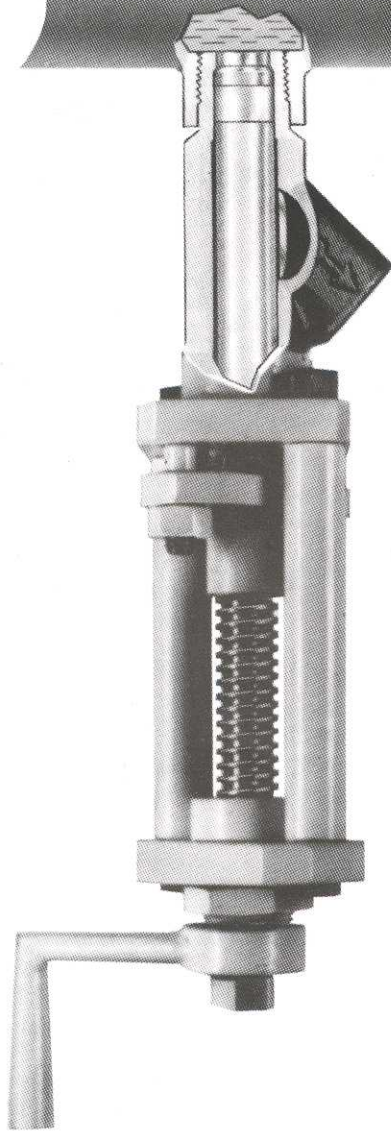

FEATURES

- 45° BRANCH ... HIGH Cv
- NON-CLOGGING ... SELF-CLEANING
- REVERSE FLOW CAPABILITY
- FULL-PORT FLOW CHANNEL
- CAVITY-FREE – NON RESIDUAL PRODUCT
- ELIMINATES ODD-ANGLE PIPE FITTINGS

RAM-SEAL[®]
SAMPLING / INJECTOR VALVE

RAM-SEAL[®]...

Every feature of the Fetterolf RAM-SEAL Sampling / Injector Valve has been designed into the valve to simplify the extraction of product samples or injection of media into the product tank, reactor or pipeline and to give long, troublefree and positive service in these applications. The design embodies the patented RAM-SEAL principle that has proved itself in the most severe sampling, charging, sparging, and draining services.

RAM-SEAL Valves constitute a major advancement in valve technology for control of difficult-to-handle fluid media. Originally developed for flush-bottom closure, its positive sealing achievement in viscous, slurry or pulp applications has extended its service to areas where most common valve designs have recorded less than satisfactory performance.

The Fetterolf RAM-SEAL Sampling / Injector Valve assures clog-free performance with either flush-end or penetrating plunger. A straight-neck 45° branch nozzle simplifies downstream piping and reduces pressure drop.

Nominal pressure rating of the standard valve is 600 psi. Pressure-temperature adjustment may be made to comply with applicable ANSI standards up to the maximum temperature of the seal ring material, 510°F for TFE. Other seal ring materials to 1000°F are available.

ADVANTAGES

- **REVERSE FLOW CAPABILITY** — retracting seal ring avoids impingement and abrasion by product.
- **CLOG-FREE PERFORMANCE** — automatic rodding on every stroke.
- **OBSTRUCTION-FREE FLOW** — no valve stem within product stream.
- **45° BRANCH** — permits piping installation with standard fittings. Higher Cv than 60° patterns.
- **INTEGRAL HEATING JACKETS** - totally envelop valve body for high heat transfer rates.
- **COMPENSATION FOR SEAL RING WEAR** — valve stays in service longer between maintenance periods.
- **EXTENDED PLUNGER OPTION** — permits ramming to or beyond flush surface of pipe or vessel.
- **FULL ACME STEM THREADS** — diameter and pitch selected to prevent stem back-off under high system pressure or vibration.
- **HIGH PRESSURE CAPABILITY** — models available for 1500 psi and 2500 psi service.

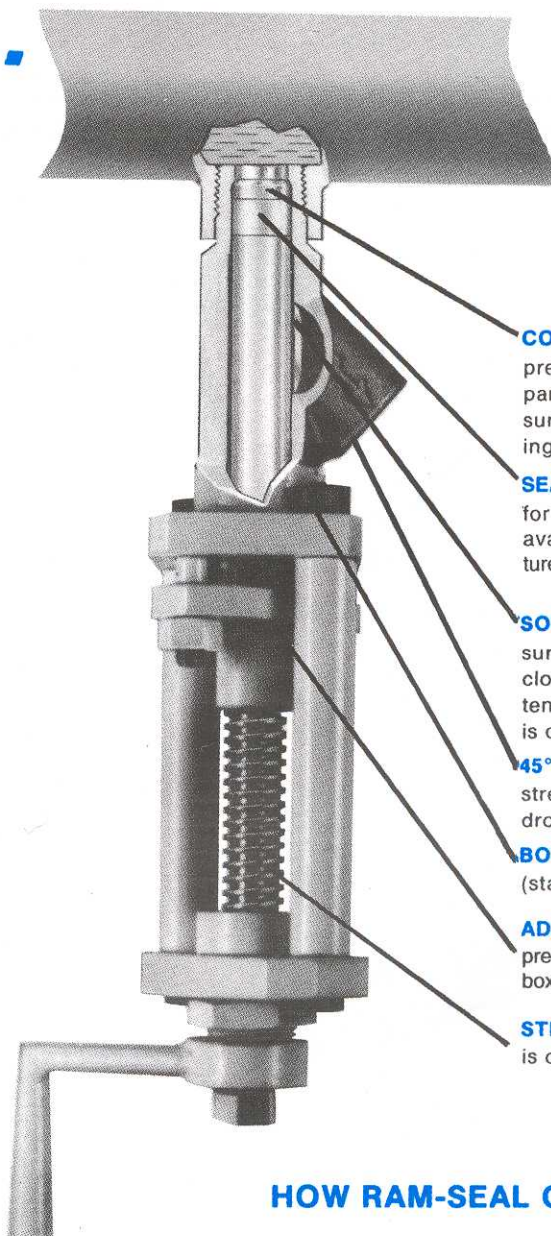

COMPRESSION RING exerts compressive force against seal-ring. Expands ring against polished seating surface in body wall. Drop-tight seating when valve is closed.

SEAL RING is TFE (standard), suitable for service to 510°F. Other materials available for higher service temperatures.

SOLID PLUNGER is flush with inner surface of pipe or vessel when valve is closed; displaces full bore of valve. Extended plunger for greater penetration is optional.

45° BRANCH NOZZLE permits streamlined flow with low pressure drop. Higher Cv than 60° outlets.

BODY is Type 316 stainless steel (standard). Other materials available.

ADJUSTABLE GLAND sets and holds pressure on gland packing. Deep stuffing box controls leakage.

STEM with self-locking ACME thread is oversize for longer wear.

HOW RAM-SEAL OPERATES

The basic action is that of a piston operating within a cylinder. When the valve is in its closed position, the piston or plunger occupies the entire inner bore of the valve leaving no space for particles to build up to a clogging condition. Unlike other valves of the ram or seatless families, the resilient seal-ring is mounted on the plunger and travels with it through its stroke. In closed position it receives the reactive force of a compression ring and is expanded in to a wide-band seal against the surface of the valve body. In open position it is retracted into the bonnet of the valve where it is protected from the abusive forces of velocity and high pressure drop. Through the entire stroke the seal ring makes sliding contact only for a short distance it traverses the polished seating surface of the body.

ACTUATION

Although most S/I valves are fitted for manual (hand-crank) operation, all have the capability for remote and automatic actuation. Fetterolf Valves are available with air or hydraulic cylinders, air turbine motors and electric motors. Additionally, position indicating switches and fail-safe devices may be specified.

SIZES

FETTEROLF RAM-SEAL Sampling/Injector Valves are available in the sizes listed below.

Fig. No.	SIZE (NPT)*	
	Body (Male)	Branch (Female)
9115	1/2"	1/2"
9115	3/4"	1/2"
9115	1"	1/2"
9117	3/4"	3/4"
9107	1"	1"

WEIGHT:
6³/₄ lbs.
(3.1 kg.)

*Note: **Fetterolf Flanged RAM-SEAL Drain Valves** 1¹/₂" through 12", for pressures to 5000 psi are described in separate bulletins.

MATERIALS

In addition to the standard materials listed below, valve bodies and wetted parts may be specified in a variety of metals including Type 304 stainless steel, titanium, nickel, Monel, Inconel, and Alloy 20. We will fabricate to the customer's specifications.

No.	PART NAME	MATERIAL
1	Body	Stainless Steel, Type 316
2	● Stem	Stainless Steel, Type 416
3	Yoke Post	Stainless Steel
4	● Yoke Bushing	Stainless Steel, Type 416
5	● Lock Nut	Stainless Steel, Type 416
7	Handle	Malleable Iron
8	● Plunger Head (Nut)	Stainless Steel, Type 316
12	● Seal Ring	TFE to 510° F*
14	● Compression Ring	Stainless Steel, Type 316
17	● Plunger	Stainless Steel, Type 316
19	● Packing Ring	TFE
20	Gland Bushing	Stainless Steel, Type 316
21	Gland Flange	Stainless Steel, Type 316
22	● Plunger Drive Bushing	Stainless Steel, Type 416
23	Stem Nut	Steel

● Denotes Recommended Spare Parts

*Other materials to 1000° F

HOW TO ORDER

To facilitate prompt handling of your order, please specify the following:

- Quantity
- Fetterolf figure number
- Metallurgy of body and wetted parts
- Flush or desired plunger penetration dimension
- Type of adapter, if required. Give pertinent dimensional information: thickness of pipe or vessel wall, bore of entry hole, size of pipe, etc.
- Service and product handled.
- Pressure and temperature, maximum.

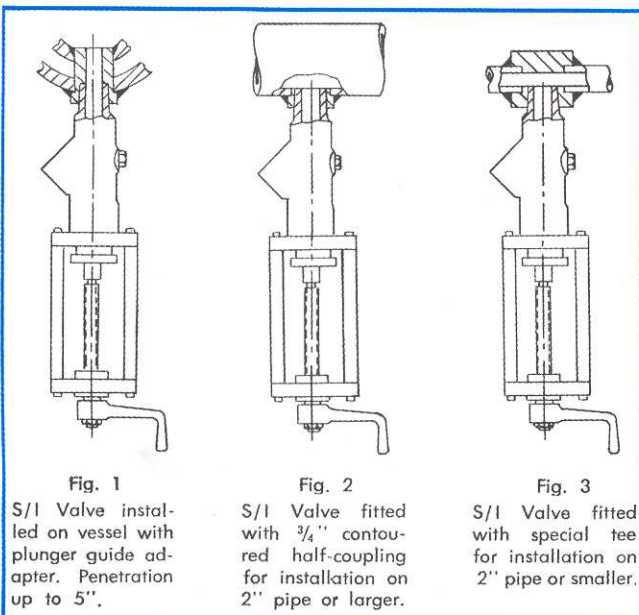
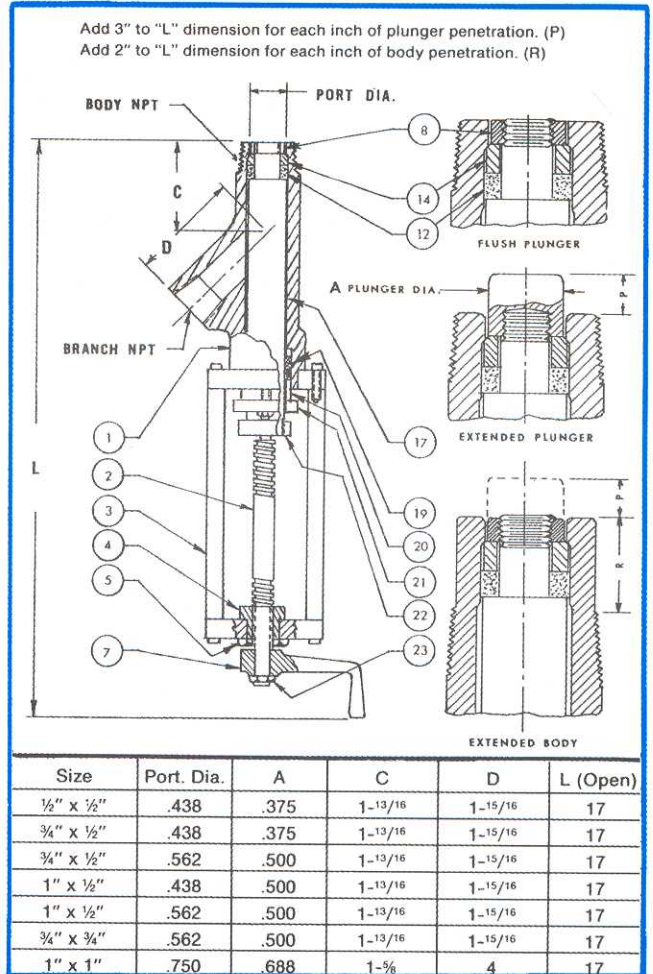

INSTALLATION

The **Fetterolf S/I Valve** is provided with NPT male body and female branch connections. Attachment to a pressure vessel, reactor or tank may be accomplished by direct connection into a tapped hole, or, for walls of greater thicknesses, by employing a plunger guide adapter (Fig. 1) to house the elongated plunger. Installation into piping is accomplished either directly or with the use of one of the **Fetterolf Adapters**, the contoured half-coupling (Fig. 2) or the companion tee (Fig. 3), as shown at the left.

Branch piping from the valve is assembled with readily available 45° and 90° standard fittings of proper material. No special odd-angle elbow or mitre fittings required.

FETTEROLF

RAM-SEAL®

THERE IS A FETTEROLF VALVE TO HANDLE JUST ABOUT EVERY CORROSIVE OR ABRASIVE FLUID AT PRESSURES FROM 5500 PSI DOWN TO VACUUM. IF WE DON'T ALREADY MAKE IT, WE'LL DESIGN AND FABRICATE TO YOUR EXACT REQUIREMENTS. HERE ARE JUST A FEW VALVES DEVELOPED FOR A SPECIFIC NEED BUT NOW CONSIDERED "STANDARD."

FETTEROLF RAM-SEAL VALVES

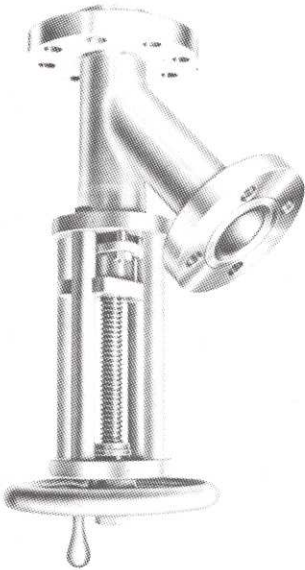

Fetterolf RAM-SEAL VALVES - Although originally designed as a Flush-Bottom Tank Valve, exceptional performance at high pressures and with highly abrasive media has led to its specification in line shut-off services as well. The RAM-SEAL concept has been adapted into valve bodies in many configurations. Pictured here is the standard Tank Valve. Jacketed models are also standard.

FETTEROLF SAMPLING ASSEMBLIES



Fetterolf SAMPLING ASSEMBLIES - Custom fabricated assemblies for in-line drain or sampling applications include the Fetterolf valve of desired pipe size, welded to a short section of the process pipe. Considerable savings in field installation plus the higher quality assured by controlled shop-welding are benefits to the project. Pictured above is a heat-jacketed valve welded to sections of both the process pipe and the jacket pipe.

FETTEROLF STRAIGHTWAY VALVES

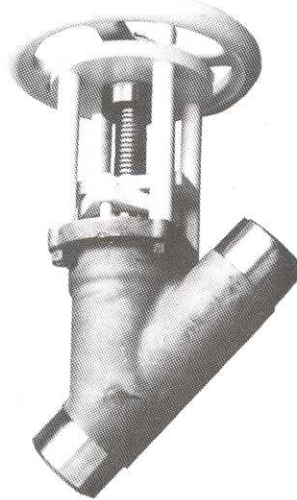

Fetterolf STRAIGHTWAY VALVES - Wye pattern body for straight-through flow providing low pressure drop combined with high Cv. eliminates internal pockets or stagnant areas. Utilizes the proven RAM-SEAL principle of closure for use from full vacuum to 5000 psi. Sizes 1/2" through 6" in ANSI pressure classes 150-2500. Flanged and welded ends available in all metallurgies. Manual, pneumatic, and electric actuation. Heating jackets and lantern ring designs available. Ideal replacement for leaking ball and plug valves.

FETTEROLF SPRAY-RINSE VALVES



Fetterolf SPRAY-RINSE VALVES - These valves, utilized for reactor or tank washdown, emit a strong spray pattern to dislodge residue from the vessel walls without need to open the head of the vessel. Greatest benefit is the increased in-process time (more batches per day). Users also report a substantial reduction in volume of treated water consumed and more effective cleansing action. All-stainless construction is standard.

OTHER FETTEROLF PRODUCTS

• VALVE-PIPING ASSEMBLIES

• RAM-SEAL® TANK VALVES

• CAM-SET® LINE BLINDS

FETTEROLF CORPORATION

P.O. Box 103 • Skippack, PA 19474 • U.S.A. • Telephone: (610) 584-1500 • Fax: (610) 584-5904

website: www.fetterolfvalves.com

Call for application assistance around the world.

Argentina • Canada • China • Ireland • Italy • Korea • Mexico • Singapore • Spain • Taiwan • Venezuela