

# Automatic Recirculation Valves

PUMPENSCHUTZVENTILE



**SchuF**  **FETTEROLF**

# Automatic Recirculation Valves

An automatic recirculation valve (ARC valve) is a multi-functional valve whose primary purpose is to ensure that a pre-determined minimum flow is assured through a centrifugal pump at all times. This is important as centrifugal pumps suffer from over heating and cavitation and can be permanently damaged if they run dry.

## ARC Valve Design

SchuF Fetterolf manufactures several standard automatic recirculation valves as well as customised designs for special process requirements and severe operating environments. The standard SchuF ARC valve SureFlo™ design is illustrated opposite.

## SureFlo™ Operating Principles

The Automatic Recirculation Valve is installed in the pump discharge line in the position of the main check valve that it replaces. The valve opens as soon as the pump builds sufficient flow to move the internal valve disc in the main line into an open position. Decreasing flow through the valve causes the spring loaded disc to return to its seat closing the process outlet. Simultaneously, a bypass outlet is

uncovered allowing a minimum flow of liquid to be routed back to the pump.

## One Valve, Many Functions

An automatic recirculation valve encompasses all of the hardware required in a conventional bypass system in a single housing. The valve consists of several key parts:

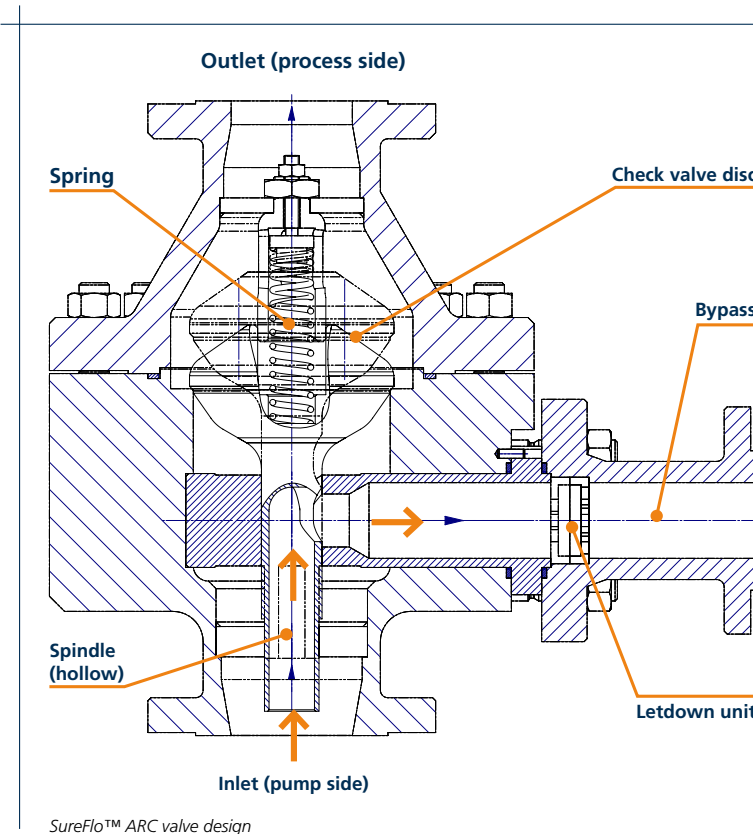

- the check valve running vertically from the pump inlet below to the outlet above, which not only protects against reverse flow, but provides excellent pulsation dampening of the fluid.
- the bypass valve operates by sensing the main flow and automatically controlling the medium flow into the bypass line. This avoids the use of any electrical power, control wiring or the need for instrument air support.
- the pressure let-down unit located in the bypass section of the valve (on the right of the drawing) is designed to handle the required pressure drop from the process to the pump inlet. The ARC valve is therefore a check, bypass, minimum flow and pressure control valve in one body.

## Features

- Modular design
- Automatic bypass operation
- Non return function
- Pressure modulation in bypass
- Self cleaning bore
- Linear or customised pressure control



# Centrifugal Pump Protection Scenarios

Centrifugal pumps transform mechanical energy into pressure energy by means of centrifugal force resulting from impeller rotation acting on the fluid within the pump. The pump requires a minimum liquid flow in order to avoid overheating. If a predefined minimum flow is not maintained, the pump can be permanently damaged. A number of different pump protection scenarios are reviewed below.

## 1) Non return scenario

The pump has no back-flow prevention and therefore product will flow back through it once it has stopped. A non return valve (NRV) is therefore usually placed after the outlet of the pump. A reservoir is used to take the pumps output when there is no process demand.

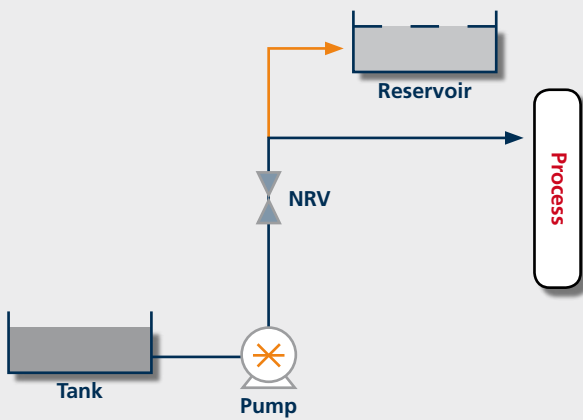

## 2) Continuous flow scenario

A manual bypass or leakage path can be added to allow the required minimum flow back to the pump inlet. This system is simple and effective, but is in constant operation and therefore is inefficient and costly (energy costs).

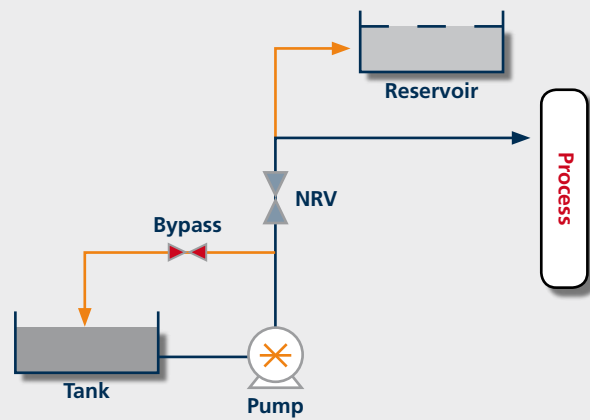

## 3) Control valve scenario

This comprehensive control valve solution is highly effective. In this scenario, a flow control valve is connected to a flow meter and allows the main line flow to be metered. As main line flow decreases the control valve opens to allow the correct minimum flow required. However, it is a highly capital intensive solution that requires flow metering equipment, control and non return valves. No reservoir is required.

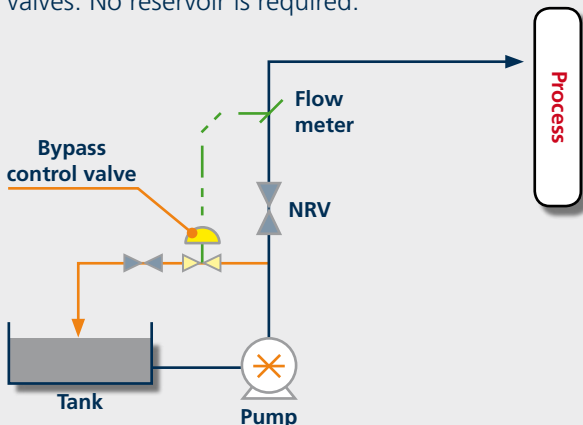

## 4) ARC valve solution

The previous approach stands and falls with the integrity of the control system and its associated cost. A safer system is to combine the non return valve, the bypass valve and the control valve into an interconnected unit, the so called "automatic recirculation valve". This valve closes when there is no flow, automatically opening the bypass line, which is sized for minimum flow. When the main line takes flow but less than minimum, the bypass line and the main line are both partially open.

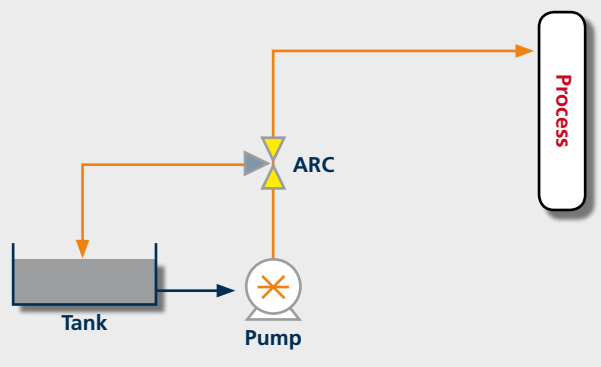

# ARC Valve Operating Conditions

## 1. Main Flow Only – Bypass Closed

When the process associated with the pump is in the normal operating condition, the main line is open. The pressure created from the media flow is sufficient to compress the spring in the check valve disc and lift it from its seat to the fully open position.

As the connected disc stem rises, the bypass exit in the stem funnel is moved against the valve body and the bypass system is closed. The recirculation flow is blocked, thus eliminating wasted energy. This is illustrated in figure 1. The bypass flow is therefore inversely proportional to the main pump flow. When the check valve is fully opened, the bypass is fully closed.

## 2. Combined Flow

As the flow requested by the process is reduced the pressure on the disc spring is lowered and the disc moves towards its seat. The check valve part of the ARC valve moves first to a partially open position (illustrated in figure 2). In this position there is partial flow to the outlet and a minimum flow to the bypass is maintained.

## 3. No Main Flow – Bypass Only

When no product is required by the process the valve disc returns to its seated position. There is insufficient flow to compress the spring and allow the disc to rise.

In this position, the curved part of the hollow stem is now flush with the entrance to the bypass funnel. A predefined minimum flow can now move from the pump through the bypass section and be recirculated to the front end of the pump. The centrifugal pump is protected from overheating or cavitation.



Figure 1

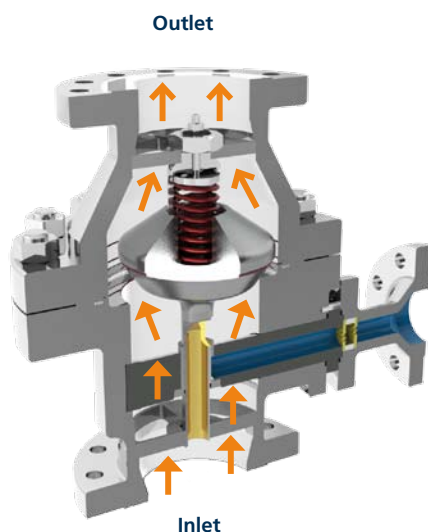

Figure 2

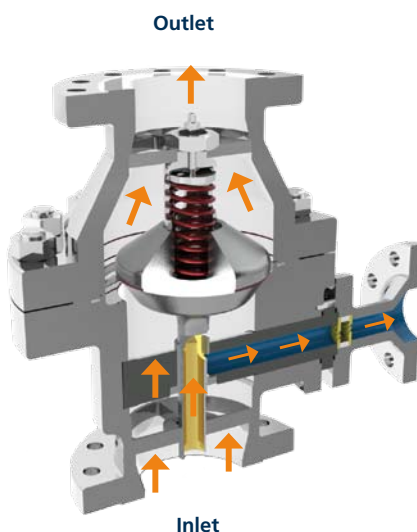
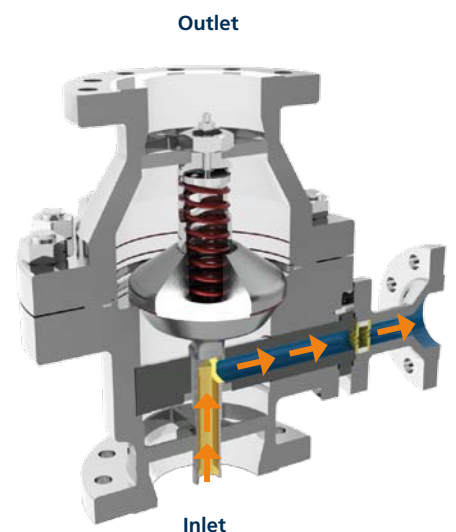

Figure 3



# ARC Valve Product Range

## SureFlo™ ARC Valve

- For 1 to 10 inch pump applications
- Fixed letdown in the bypass
- Up to ASME 2500# pressure class
- Variable bypass delay
- Fewer moving pieces
- Cast housing in CS or SS material

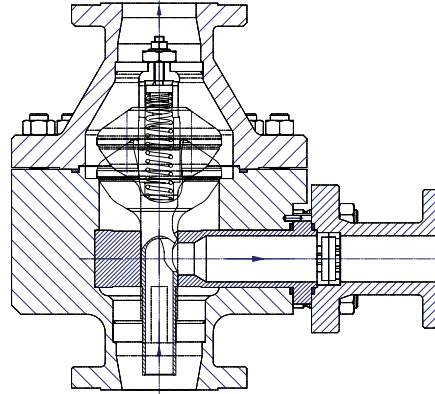

## HighFlo™ ARC Valve

- For 10 inch+ pump applications
- Fixed letdown in the bypass
- Better noise attenuation
- Up to ASME 4500# pressure class
- Variable bypass delay
- Forged or cast body

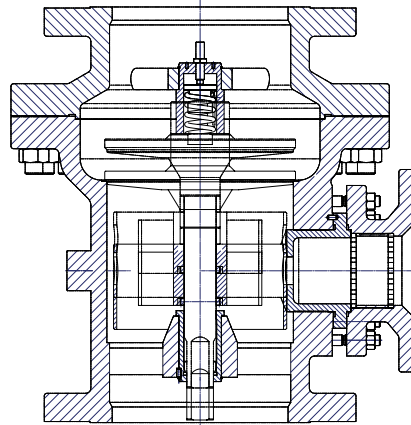

## ControlFlo™ ARC Valve

- Size independent
- High pressure design
- Multistage letdown
- Enhanced bypass sealing
- Letdown varies with stroke
- Enhanced noise attenuation
- Forged or cast body in CS or SS material
- Non return valve in bypass

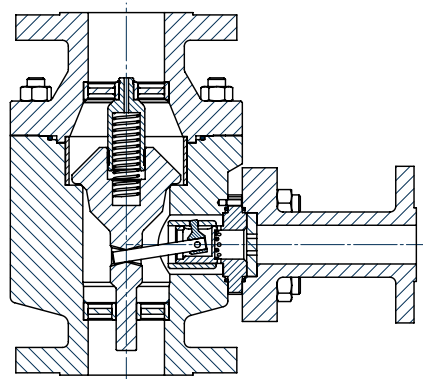

The ARC valve models illustrated above are examples of some of the standard designs available. SchuF will advise the most suitable design for your application, or can propose an alternative for special process or environmental conditions.

# Product Range & Technical Data

## Product Range

Product Range	Description
SureFlo™	1 inch (DN 25) to 10 inch (DN 250) pumps and up to ASME 2500# pressure class
HighFlo™	10 inch (DN 250) to 16 inch (DN 400) and up to ASME 4500# pressure class
ControlFlo™	for enhanced bypass sealing and multistage letdown
Maritime & Offshore ARC Valve	with special maritime body and trim material – size and pressure class as required
Custom designed ARC Valve	for special pump applications or unique operating environments and severe media

## Technical Data

ARC Valve	Standard Features	Optional Features
Application	To protect pumps and ensure minimum flow conditions	
Size	1" to 16" as standard	To 30" or larger as custom design
Body and bypass	Carbon or Stainless steel (316L)	Duplex, Hastelloy or Titanium
Valve Lining/Sleeves	n/a	Ceramic
Trim materials	Stainless steel (316L)	Duplex, Hastelloy, Ceramic, Inconel, Titanium or Tungsten Carbide for severe service applications
Spindle	Stainless steel 1.4404 (316L)	as above
Spring	Stainless steel	Inconel X750 (2.4669)
Temperature	Minus 20° to 300°C	Minus 100°C to 500°C
Process sealing	Metal to metal	n/a
Pressure rating	All up to ASME 2500 (PN320)	To ASME 4500# or higher on request
Connection types	Butt weld end or flanged (DIN or ANSI)	ISO, BS, JIS, NF on request
Heating jacket	n/a	Full or semi jacketing
Bypass trim design	Throttle plates	Multi stage, hollow, or cage trim in bypass
Control Characteristics	Linear	Equal %
Installation	Vertical	Horizontal
Flow direction	Flow to open, no reverse flow (integral check valve)	n/a
Other options	Maritime sea water service ARC design	Valves conforming to NACE MR-01-75

## ARC Valve Business Benefits

- Protects the business investment in critical pump equipment
- Saves power costs by eliminating the need for continuous recirculation to cool the pump
- Includes reverse flow protection
- Avoids additional investment in pressure reduction equipment
- Needs no electrical wiring, plant or instrument air
- Reduces downtime – and is easy to maintain

# Selected ARC Valve Dimensions and Parts List

## Dimension Table

Inlet/Outlet Size	Bypass Size	Pressure Class	a in mm	b in mm	H in mm
1"/1"; DN25/25	½"; DN15	ASME 150	188	145	271
2"/2"; DN 50/50	1½"; DN40	ASME 300	283	236	425
3"/3"; DN75/75	3"; DN75	ASME 300	277	295	420
4"/4"; DN100/100	1½"; DN40	ASME 300	297	300	450
4"/4"; DN100/100	2"; DN50	ASME 300	297	305	450
4"/4"; DN100/100	3"; DN75	ASME 300	297	310	450
6"/6"; DN150/150	3"; DN75	ASME 300	357	385	520
6"/6"; DN150/150	4"; DN100	ASME 300	357	390	520
8"/8"; DN200/200	3"; DN75	ASME 300	524	430	795

The dimension table below is for illustrative purposes for ARC valves to eight inches. SchuF can produce ARC valves in all sizes and pressure classes as required by the application or operating conditions.

## Parts List (High temperature design example)

Part	Description	Material
10	Upper body	ASTM A217 WC1
20	Lower body	ASTM A217 WC2
30	Disc with spindle	1.4404; 316L
40	Spring guide	1.4404; 316L
50	Bypass body	1.4404; 316L
60	Control bushing	1.4404; 316L
70	Bush	2.0550; Brass
80	Spring guide	1.4404; 316L
90	Letdown unit	1.4404; 316L
100	Wire wound gasket	Graphite
110	Spring	2.4669; Inconel

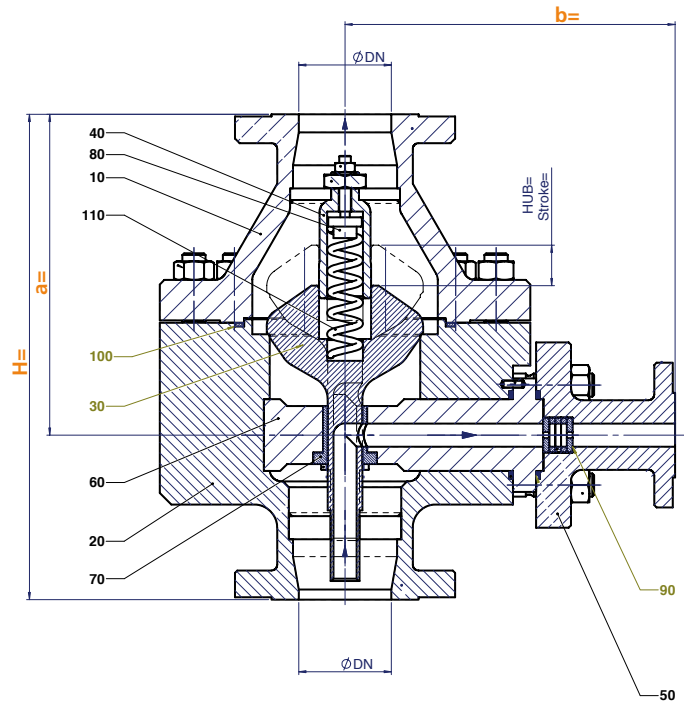

## Nominal Size and Maximum Flow Examples

Main Inlet/Outlet size		1"	1.5"	2"	3"	4"	6"	8"	10"
Max Flow	GPM	65	132	264	616	1,100	2,422	4,400	8,805
	m³/h	15	30	60	140	250	550	1,000	2,000
Bypass size		0.75"	0.75"	1"	2"	3"	4"	6"	8"
Max Flow	GPM	62	62	88	176	330	660	1,320	2,465
	m³/h	14	14	20	40	75	150	300	560

The above table is for illustrative purposes and is intended to give a quick estimate of the size of valve required based on main and bypass flow. The indicated flow values are based on fluids with a specific gravity of 1. For fluids with different specific gravity, please inquire with SchuF directly.

# Control Trim and Control Valve Options

## ARC Valve Control Trim Options

SchuF offers a variety of ARC valve control trim options. Choice will depend on many factors such as the medium, the required pressure drop, solid contents and the nature of the process. The most common form of pressure control in the bypass line is achieved via a series of nozzle plates. The required pressure drop is achieved by varying the number, size and position of the nozzles in the bypass and the number of plates used.

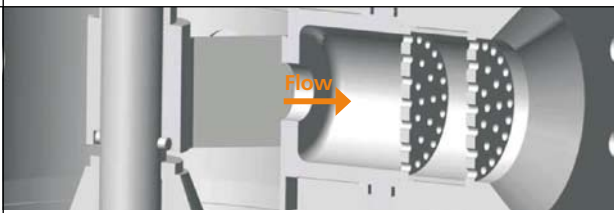

Nozzle plates in bypass letdown unit

For high pressure drop requirements, a single piece multistage disc and spindle is placed in the bypass.

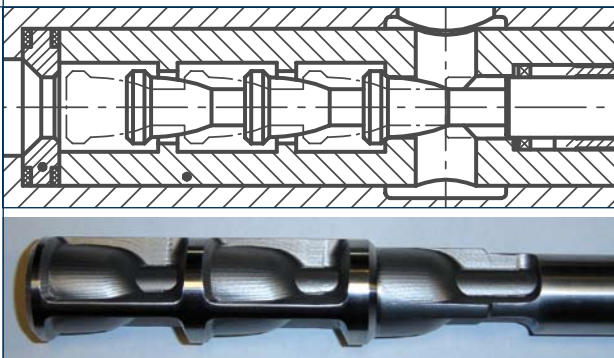

Multistage letdown disc in bypass

Pressure can then be reduced in 2, 3, or up to 6 stages. The disc contours can be varied for different media or letdown patterns.

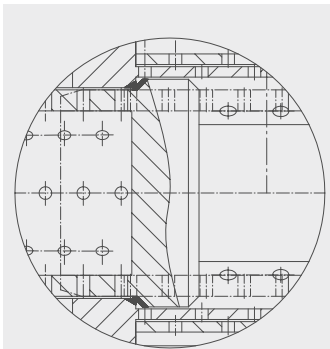

Cage labyrinth letdown design

For applications where noise or vibrations are of concern a cage labyrinth design can be used in the bypass or integrated into the main line check valve design.

## Minimum Recirculation Control Valve

Despite the diversity of control options available for the ARC valve, there are still situations where an independent control valve may be the best option.

Processes that require independent and variable control or where the media contains solid particles, crystals or is highly viscose generally require a separate control valve to protect the centrifugal pump. An example of a SchuF minimum recirculation control valve used in a severe application is shown below.

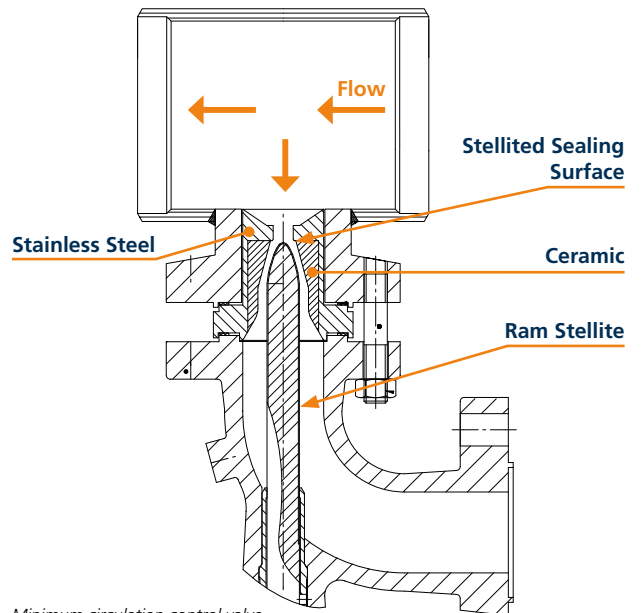

Minimum circulation control valve

The control valve shown above was designed for a severe service pump application that included a high pressure drop ( $\Delta p$  40 bar), 30% solid contents and significant flashing.

It has the following key features:

### Key Features

- Flow to open (piston opens into the valve body)
- Accelerating body geometry design
- One piece disc and spindle
- Linear or equal % control characteristics
- Standard heavy yoke (ideal for vibrating service or high delta p flow)
- Hard trim material to match process or medium conditions



# ARC Valve Applications and Media

Automatic recirculation valves have the primary purpose of protecting pumps. They are found in most industries and can be used with a broad variety of pump applications:

## ARC Valve Applications

- General centrifugal pumps
- Crude oil pumps
- Fluid gas pumps (for LNG, LPG etc.)
- Process liquid pumps
- Booster pumps
- Seawater injection pumps
- Boiler feed water pumps
- Cooling plant feed pumps
- Fire fighting pumps



*SureFlo ARC valves in a boiler feedwater application*

## ARC Valves Media and Industry Examples

Industry	Medium	P Class	Temperature	Size
Chemical plant	Various solvents	PN 16	30 °C	DN40; 1½"
Chemical plant	Butadiene	ASME 150	-4 °C	DN50; 2"
LNG plant	Fire- / Fresh- and Seawater	ASME 150	-10/+20 °C	DN300; 12"
Offshore	(HP) Methanol / LDHI	ASME 150	35 °C	DN50; 2"
Power plant	Demin. Water	ASME 150	-10/+32 °C	DN80; 3"
Power plant	Filtered Water	ASME 150	60 °C	DN100; 4"
Refinery	Drain Liquid	ASME 150	75 °C	DN80; 3"
Refinery	Oil	ASME 150	50 °C	DN80; 3"
Refinery	Hydrocarbon-fluid	ASME 150	25 °C	DN150; 6"
Refinery	Boiling Blowdown Water	ASME 150	60 °C	DN150; 6"
Refinery	Kerosene	ASME 150	-10/+20 °C	DN150; 6"
Refinery	Sour Water	ASME 300	60 °C	DN80; 3"
Refinery	Fractionated Naphta	ASME 300	275 °C	DN350; 14"
Refinery	Whole Naphta	ASME 300	84 °C	DN300; 12"
Refinery	Vacuum Gas Oil	ASME 300	243 °C	DN200; 8"
Refinery	Unstabilized Naphta	ASME 300	131 °C	DN200; 8"
Refinery	Fractionated hydrocarbons	ASME 300	354 °C	DN200; 8"
Refinery	Reflux Naphta	ASME 300	99 °C	DN150; 6"
Refinery	Premium Diesel Product	ASME 300	242 °C	DN150; 6"
Refinery	Reflux Naphta	ASME 300	99 °C	DN150; 6"
Refinery	Boiler Feed Water	ASME 300	121 °C	DN100; 4"
Refinery	LPG	ASME 300	42 °C	DN100; 4"
Refinery	Whole Naphta	ASME 300	108 °C	DN100; 4"
Refinery	Heavy Gas Oil	ASME 300	353 °C	DN100; 4"
Refinery	Stabilized Naphta	ASME 300	40 °C	DN100; 4"

# Automatic Recirculation Valve – Data Sheet

Please use this data sheet to send your inquiries to us. Items marked in bold print indicate essential information.

## Part 1 – Company Information

Name: .....	Title: .....
Company: .....	Project Name: .....
E-mail: .....	Application: .....
Telephone: .....	Fax: .....

## Part 2 – Order Information

General:	Quantity: .....
	ARC Valve Type: .....
	Valve Model: ..... <b>Automatic Recirculation Valve</b> ..... Model 78PS

## Part 3 – Valve and Process Information

Valve Information:	Valve Inlet Size (DN/Inch): .....	Pressure (bar/psi): .....
	Valve Outlet (DN/Inch): .....	Pressure (bar/psi): .....
	Bypass Outlet (DN/Inch): .....	Pressure (bar/psi): .....
	Installation – Vertical: .....	or Horizontal: .....
	Materials (if known) – Housing: .....	Trim: ..... Other: .....

Process Information:	Process: .....	Liquid or Gas: .....	PED Group 1 or 2: .....
	Medium: .....	Op. Temperature: ..... C°	Fluid Vapor Pressure: .....
	Density: ..... kg/m <sup>3</sup>		

Pump Information:	Q <sub>min</sub> = ..... m <sup>3</sup> /h	H <sub>M</sub> = ..... m	Suction pr. P <sub>v</sub> : ..... (bar/psi)
	Q <sub>100</sub> = ..... m <sup>3</sup> /h	H <sub>100</sub> = ..... m	Differential pr. (p <sub>1</sub> -p <sub>N</sub> ): ..... (bar/psi)
	Q <sub>max</sub> = ..... m <sup>3</sup> /h		Backpress. P <sub>N</sub> : ..... (bar/psi)
			Backpress. P <sub>I</sub> : ..... (bar/psi)

## Part 4 – Please use the charts below to define the information required in part 3

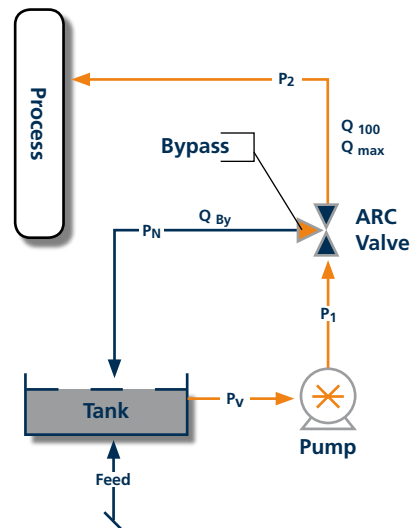
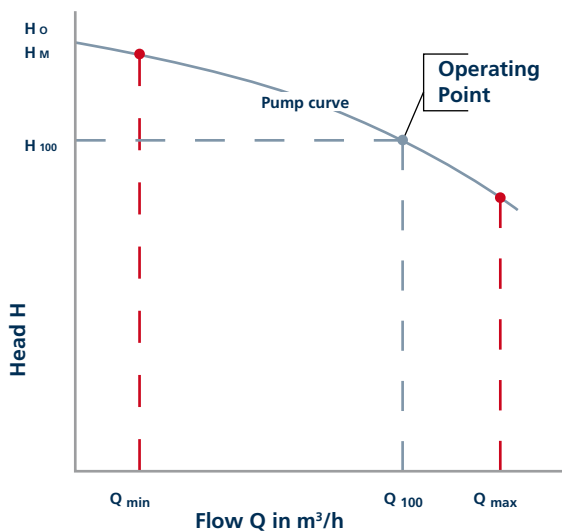

Notes: .....

.....

Send To: SchuF Fetterolf    E-Mail: valves@schuf.com    Fax: +49 6198 571200

# SchuF Fetterolf Valve Portfolio

SchuF Fetterolf has delivered over one million valves during its almost 100 year history to a wide variety of industries in over 75 countries worldwide.

Headquartered near Frankfurt in Germany, the company has additional design and manufacturing centres in Brazil, India, Ireland and the United States.

The SchuF group has sales and agent offices covering almost every country in the world.

We manufacture valve products that control, isolate, divert, and sample liquids, gases, powders, and slurries. Our product range of engineered, customised valves include:

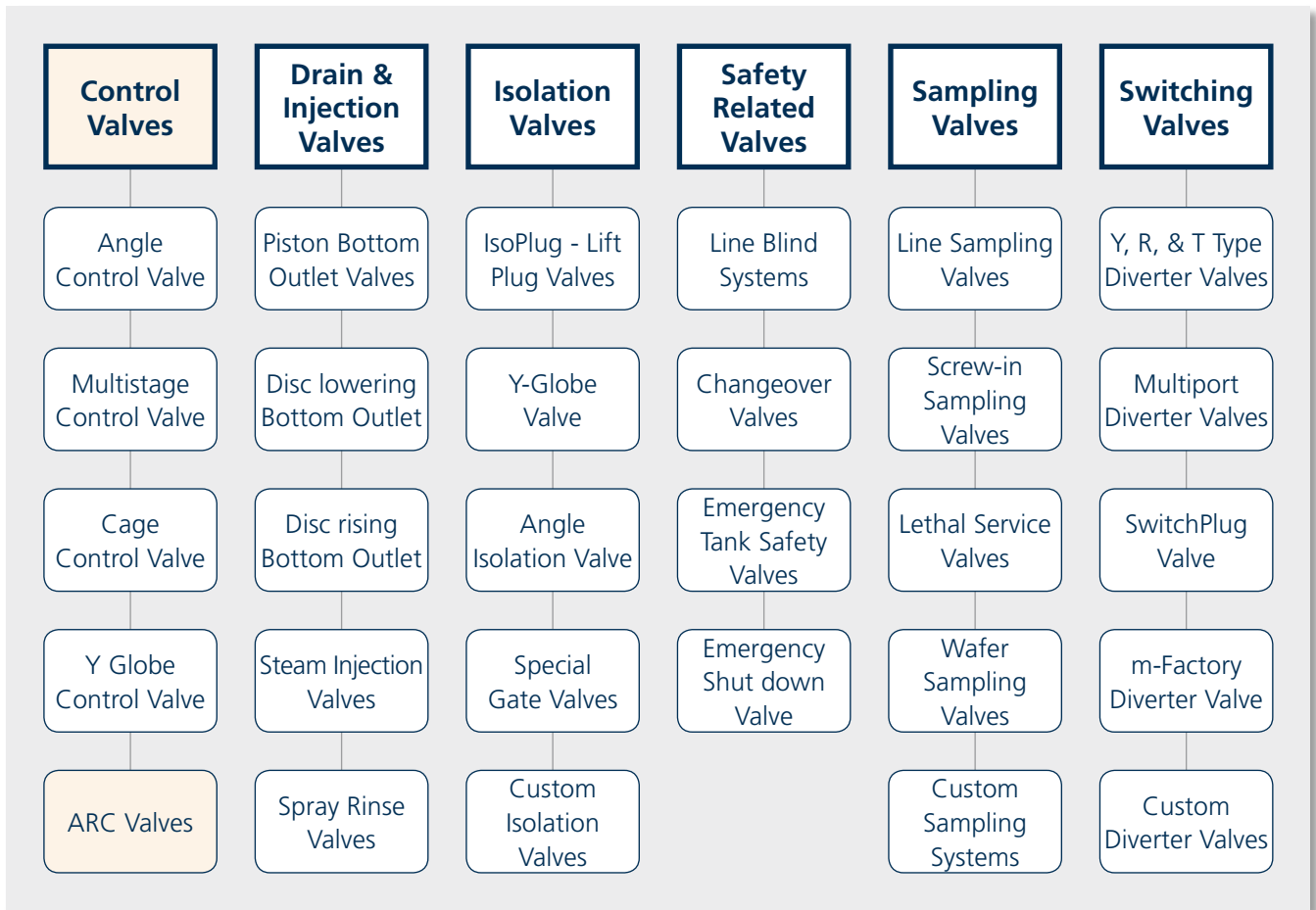

## Sample ARC Valve Client List:

- Shell
- Petrobras
- Petronas
- Conoco Phillips
- Peru LNG
- Sabic
- Samsung
- Fluor
- Foster Wheeler
- CBI
- Malaysian Refining Company
- BASF
- General Electric
- BP
- Bayer
- Exxon
- Reliance



Model 78PS ARC Valve

# SchuF FETTEROLF Worldwide

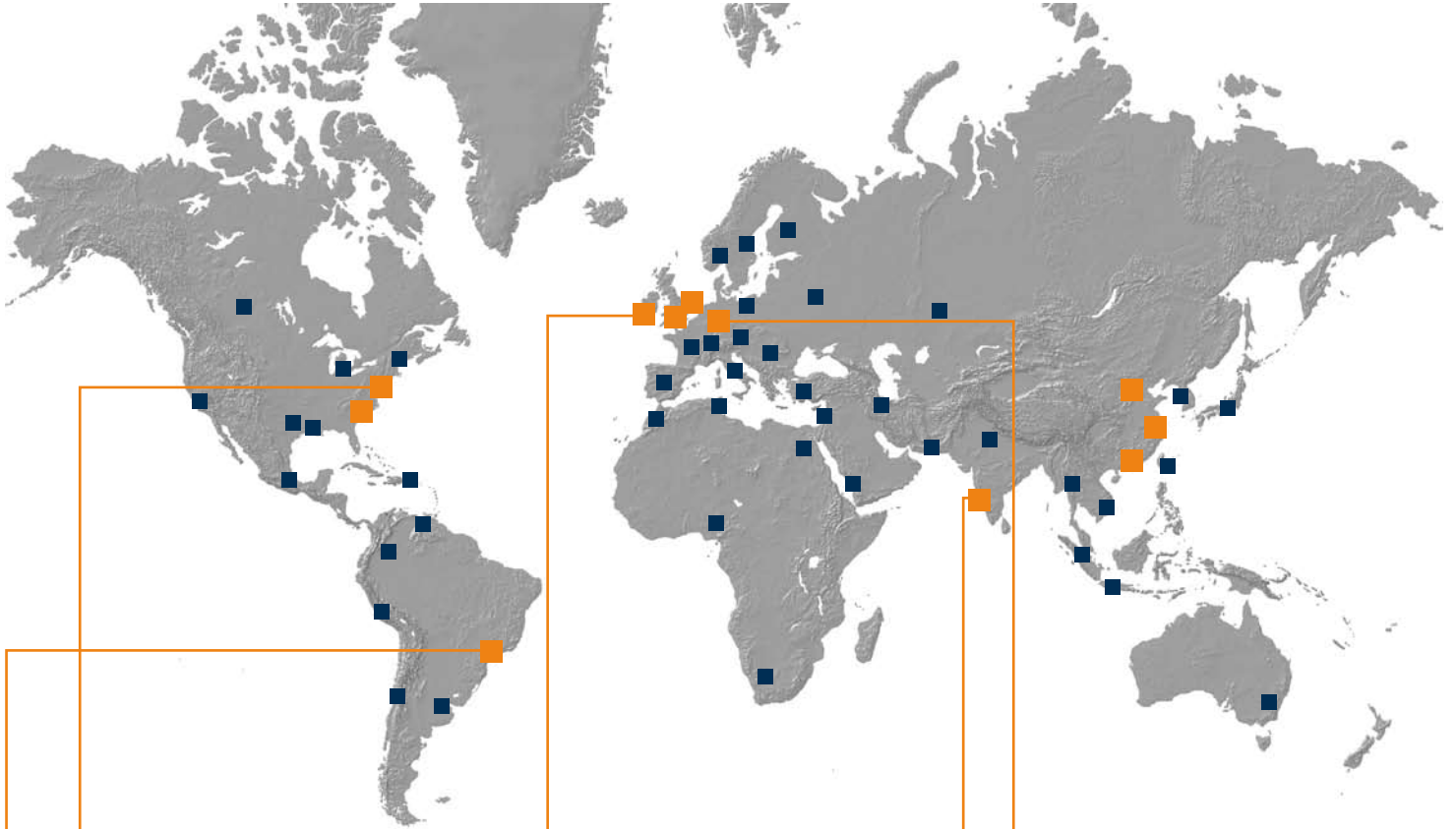

[www.schuf.com](http://www.schuf.com) · [www.schuf.de](http://www.schuf.de)

## USA



**Fetterolf Corporation, Inc.**  
phone: +1 610 584-1500  
fax: +1 610 584-5904  
[info@fetterolfvalves.com](mailto:info@fetterolfvalves.com)

**SchuF (USA) Inc.**  
phone: +1 843 8813345  
fax: +1 843 8816121  
[sales@schuf.us](mailto:sales@schuf.us)

## IRELAND



**SchuF Valve Technology GmbH**  
phone: +353 (0)21 4837000  
fax: +353 (0)21 4837030  
[sales@schuf.ie](mailto:sales@schuf.ie)

## GERMANY



**SchuF Chemieventile Vertriebs GmbH**  
phone: +49 (0)6198 571100  
fax: +49 (0)6198 571200  
[verkauf@schuf.de](mailto:verkauf@schuf.de)

## BRAZIL



**SchuF Fetterolf do Brazil Ltda**  
phone: +55 19 39369090  
fax: +55 19 39353215  
[fbvendas@fetterolf.com.br](mailto:fbvendas@fetterolf.com.br)

**Your Local Agent:**

## INDIA



**SchuF Speciality Valves India Pvt. Ltd.**  
phone: +91 421 2264600  
fax: +91 421 2362018  
[sales@schuf-india.com](mailto:sales@schuf-india.com)